

LOC	DIST	P	F	ZONE	LTR	DESCRIPTION	DATE	APPD
AF	50				E	REV PER 0G1A-0048-99	04JUN99	JR/DD

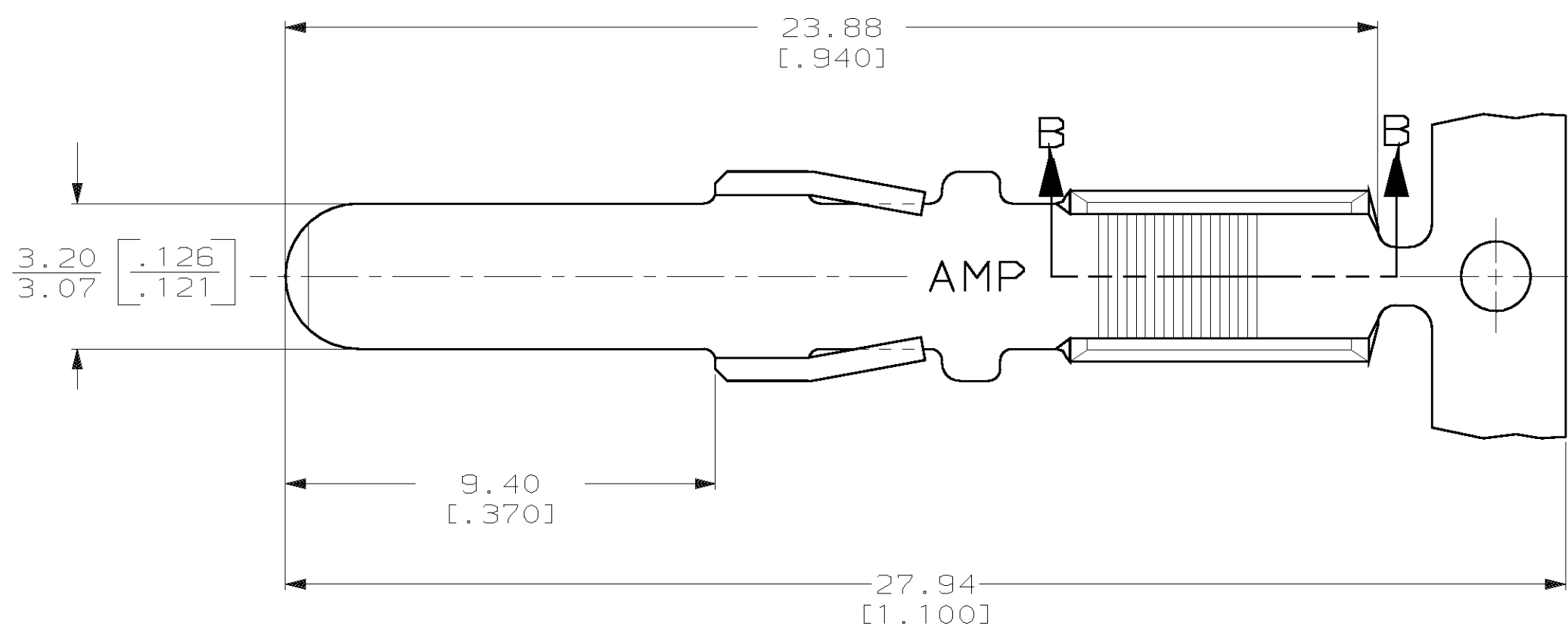

1 CONTINUOUS STRIP ON REEL.

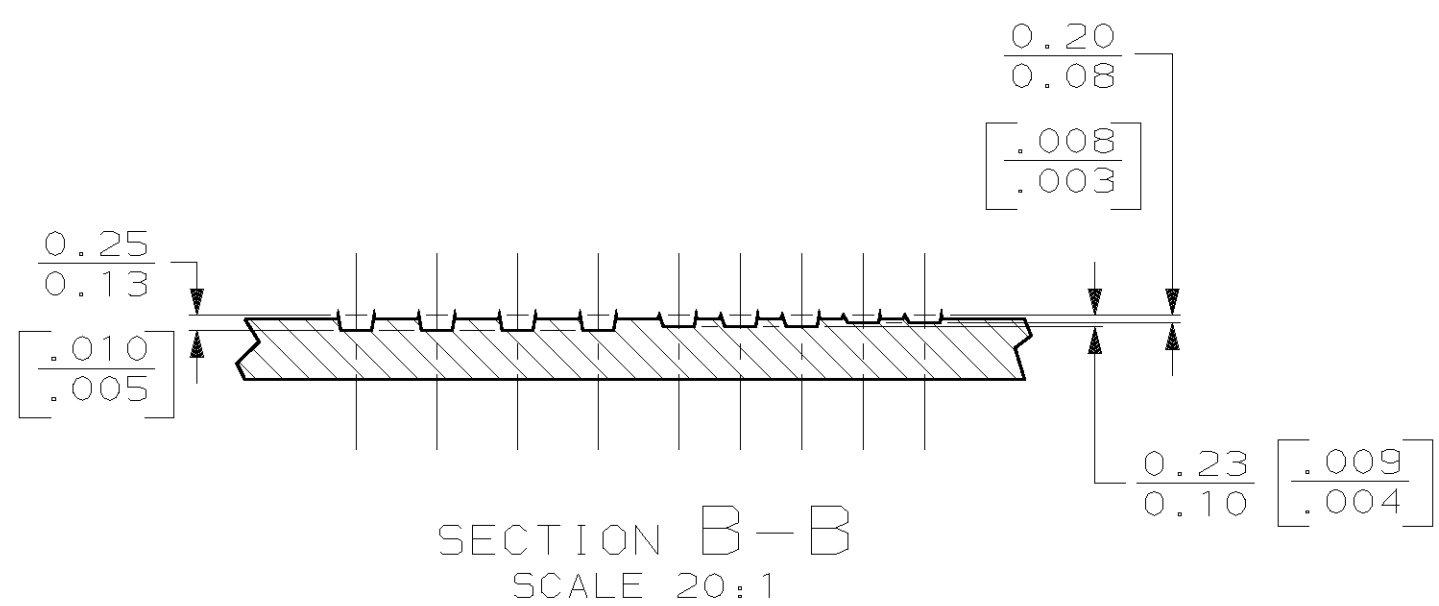
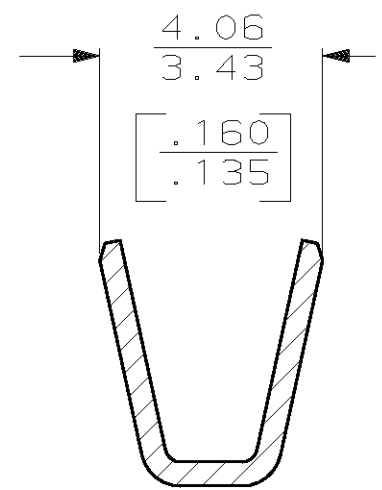
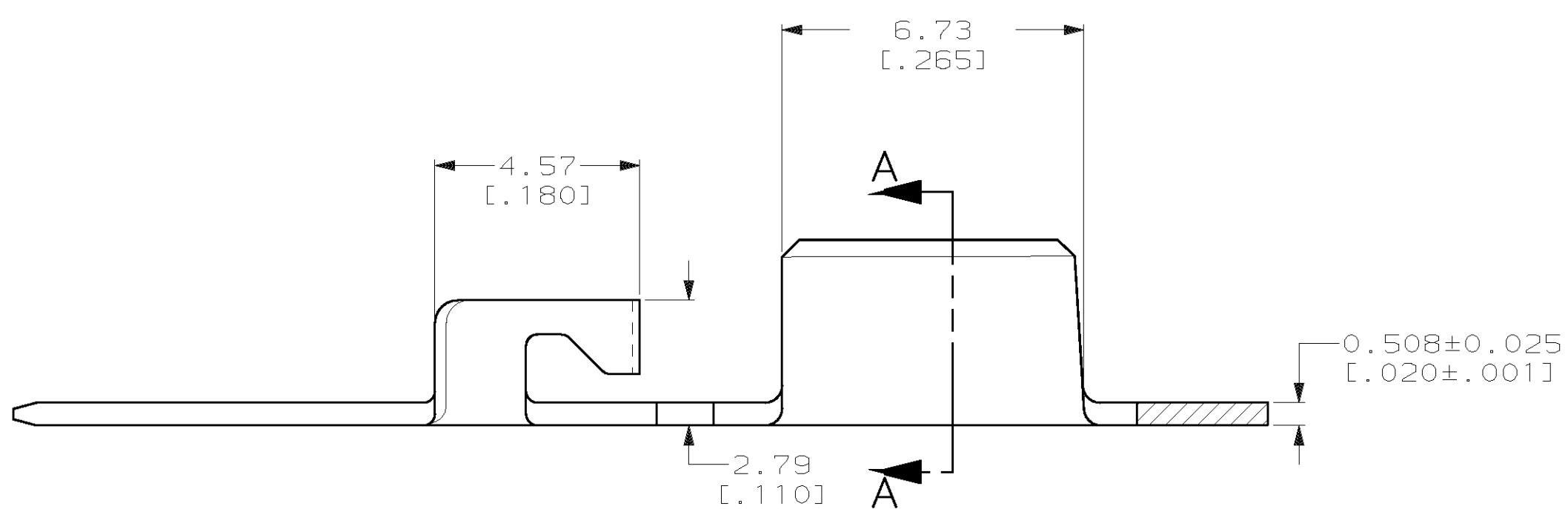
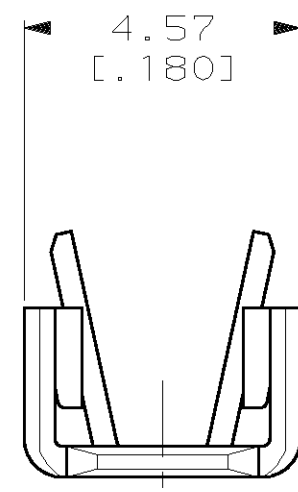

1500-5000 CMA	1217073-1
WIRE RANGE	PART NO

DO NOT SCALE PRINT. UNLESS SPECIFIED DIMENSIONS IN mm [INCHES] TOLERANCES ON: 2 PLC DEC ± 0.25 [.010] 3 PLC DEC ± - ANGLES ± -	DR 3/10/98 JR RUTH	AMP Incorporated Harrisburg, PA 17105-3608
	CHK 3/10/98 P FORTNEY	
MATERIAL 4M BRASS	APPD 3/10/98 DON DECKER	NAME CONTACT, 3.18 [.125] BLADE, AMPLIVAR
FINISH 0.002032 [.000080] MIN TIN PL PER MIL-T-10727	APPD 3/10/98 D BRATINA	PRODUCT SPEC -
THIS DRAWING IS A CONTROLLED DOCUMENT FOR AMP INCORPORATED. IT IS SUBJECT TO CHANGE AND THE CONTROLLING ENGINEERING ORGANIZATION SHOULD BE CONTACTED FOR THE LATEST REVISION.	APPLICATION SPEC -	SIZE C 00779
	WEIGHT -	CAGE CODE G=1217073
		DRAWING NO G=1217073
		SCALE 8:1
		SHEET 1 OF 1